

# Field Cabinet Accessories

# IP-FCBASE

## STEEL | PEDESTAL BASES

## Suited for Pole-Mounted Field Cabinets

IP Enclosures steel pedestal bases provide a robust mounting solution for both ventilated and non-ventilated pole-mounted field cabinets. Offered as an accessory, they enable secure installation directly onto floors or ground surfaces.

**Standard:** IEC/EN 60529, IEC/EN 62208, EIA-310-D, RoHS



**Material:**

- Body: 1.5mm galvanised steel sheet

**Body:** The robust body is fabricated from 1.5mm galvanised steel sheet.

**Surface Treatment:** UL approved AkzoNobel polyester powder coated with a smooth gloss finish, 80-120 micron average thickness, providing excellent exterior durability and colour retention.

**Standard Colour:** T33 Smoke Blue.



Image shown is for reference only. See table below for the accurate sizes and specifications.

**Pedestal Base - T33 Smoke Blue:**

Part Number	Pedestal Base size	To suit Non-Ventilated / Ventilated Field Cabinets	Weight
SKU	H x W x D (mm)		Kilogram (Kg)
IP-FCBASE3522-T33	600H x 350W x 225D	IP-453522-0-T33; IP-453522-T33	10
IP-FCBASE4532-T33	600H x 450W x 325D	IP-654532-0-T33; IP-654532-T33	13
IP-FCBASE6032-T33	600H x 600W x 325D	IP-706032-0-T33; IP-706032-T33	15

**Pedestal Base - WGN Wilderness Green:**

Part Number	Pedestal Base size	To suit Non-Ventilated / Ventilated Field Cabinets	Weight
SKU	H x W x D (mm)		Kilogram (Kg)
IP-FCBASE3522-T33	600H x 350W x 225D	IP-453522-0-WGN; IP-453522-WGN	10
IP-FCBASE4532-T33	600H x 450W x 325D	IP-654532-0-WGN; IP-654532-WGN	13
IP-FCBASE6032-T33	600H x 600W x 325D	IP-706032-0-WGN; IP-706032-WGN	15

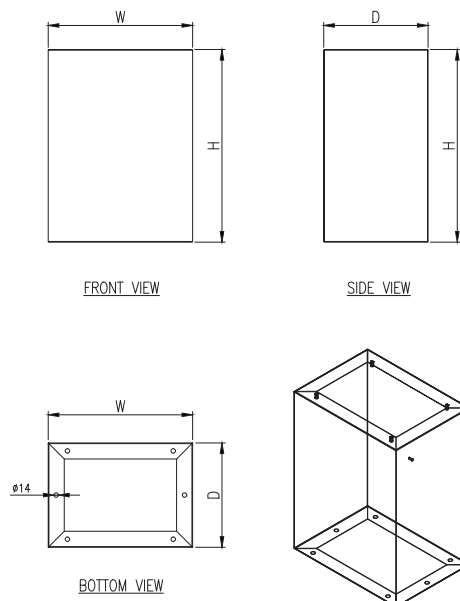

**NOTE:** 2D drawing is for visual representation only. See CAD files for accurate details and dimensions.