

316 STAINLESS STEEL | IP66

Inspection windows provide safe visibility to view and monitor equipment and components mounted inside an electrical enclosure without opening the enclosure door.

Opening Size: 125 H x 125 W

Protection: IP66

Material:

- Frame: Grade 316/316L Stainless Steel
- Window: 4.0mm Polycarbonate



Surface Finish: 0.4 micron Ra surface brushed finish.

Frame: The frame and backing flange are fabricated using Grade 316/316L Stainless Steel. A gasket is provided.

Window: The window is manufactured from 4.0mm Polycarbonate.

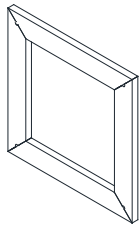

ISOMETRIC VIEW

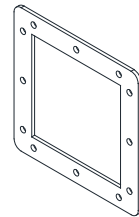

ISOMETRIC VIEW

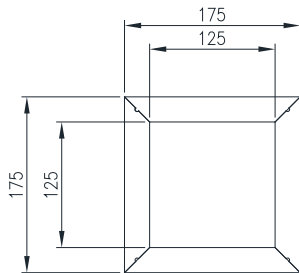

FRONT VIEW
MAIN FRAME

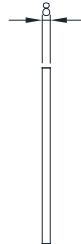

SIDE VIEW
MAIN FRAME

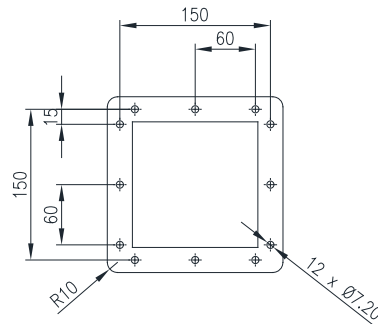

BACKING FLANGE

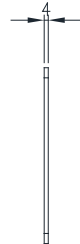

SIDE VIEW

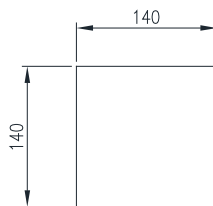

FRONT VIEW
POLYCARBONATE WINDOW



SIDE VIEW