

550m3/hr - 700m3/hr 325mm x 325mm

IP Enclosures provide a wide range of ventilation products for electrical enclosures. The front-opening grille allows filters to be easily maintained from the outside of the enclosure. All molded parts are made of highly resistant and self-extinguishing ABS. IP Enclosures ventilation products are manufactured to the highest quality in Italy.

Protection: IP54 (or IP55 if used with High Efficiency Filter Mat IP-VFXX or Vent Hood)

Conformity: 

Material: ABS UL94V-0 Colour RAL7035(Optional Colour Black)

Flow Direction: Reversible



Features	Unit	IP-V5000	IP-V5400	IP-V5401	IP-V5440	IP-V5500	IP-V5501
Air flow rate (free blow)	m3/h	-	550 (620)			700 (770)	
Air flow rate with exit filter	m3/h	-	405 (450)			520 (575)	
Power supply	V/Hz	-	230 / 50-60	115 / 50-60	400 / 50-60 / 3~	230 / 50-60	115 / 50-60
Dimensions HxWxD	mm	325x325x42	325x325x140			325x325x154	
Power consumption	W	-	70 (90)		60 (70)	130 (180)	
Current consumption	A	-	0.40 (0.38)	0.80 (0.76)	0.18 (0.15)	0.55 (0.81)	1.10 (1.62)
Overcurrent protection	-	-	thermal				
Electrical connection	-	-	3-poles spring terminals *		4-p s t*	3-poles spring terminals *	
Duty cycle	-	-	100%				
Operating temperature	°C (°F)	-10 / +70 (+14/+158)					
Protection degree / Class	-	IP54	IP54 / Class I				
Noise level	dB(A)	-	65 (68)			72 (73)	
Flow direction	-	-	reversible, default factory setting outside-in				
Bearing	-	-	ball				
Filter mat EN779	-	G3	G3				
Service life (at 40°C)	hr	-	50 000				
Material	-	ABS UL94V-0 color RAL7035					
Wall thickness	mm	1.2 - 2.4					
Gasket	-	foam seal gasket					
Weight (with packaging)	kg	0.90(1.04)	3.00(3.25)			3.55(3.80)	
Package dimensions	mm	340x340x45	340x340x175				
Mounting	-	fast clip-on					
Conformity/Certifications	-	CE					

* 0.5-2.5mm²

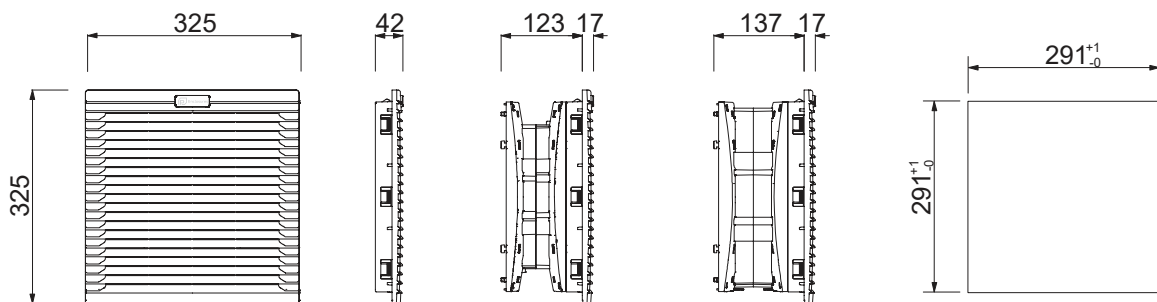

IP-V5400

IP-V5000

IP-V5400-5448

IP-V5500-5501

Cut-Out Dimensions

550m³/hr - 700m³/hr 325mm x 325mm

