

## Polycarbonate | UV Protection | IP55 High Efficiency (G4)

IP Enclosures provide a wide range of ventilation vents for electrical enclosures. For the UV range, all moulded parts are made of UV-resistant polycarbonate. The front-opening grille allows filters to be easily maintained from the outside of the enclosure. IP Enclosures ventilation products are manufactured to the highest quality in Italy.

**Standards:** EN60335-1, EN55014, EN6100-3-2, EN60529, Compliant to relevant Australian Standards, CE

**Material:** Polycarbonate, UV Protection, RAL7035 Grey

**Protection:** IP55

**High Efficiency Filter:** Self-extinguishing G4 synthetic fibre mat

Features	Unit	IP-V5000-UV
Air flow rate (free blow)	m3/h	-
Air flow rate with exit filter	m3/h	-
Power supply	V/Hz	-
Dimensions HxWxD	mm	325x325x42
Power consumption	W	-
Current consumption	A	-
Overcurrent protection	-	-
Electrical connection	-	-
Duty cycle	-	-
Operating temperature	°C (°F)	
Protection degree / Class	-	IP55 / Class I
Noise level	dB(A)	-
Flow direction	-	-
Bearing	-	-
Filter mat EN779	-	G4
Service life (at 40°C)	hr	-
Material	-	Polycarbonate; Colour RAL7035
Wall thickness	mm	1.2 - 2.4
Gasket	-	foam seal gasket
Weight (with packaging)	kg	0.90 (1.04)
Package dimensions H x W x D	mm	340x340x45
Mounting	-	fast clip-on
Conformity/Certifications	-	(Refer to the details above)

\*0.5-2.5mm<sup>2</sup>



### Easy Maintenance



1. Open Grille



2. Remove Filter



3. Insert Filter



4. Close Grille

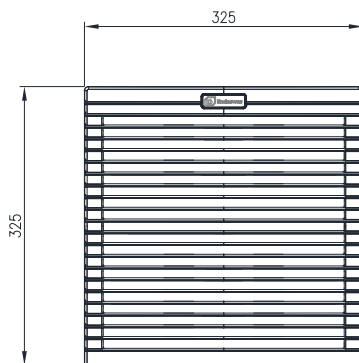

FRONT VIEW

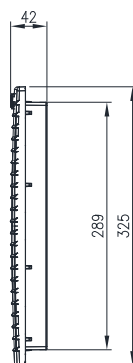

SIDE VIEW

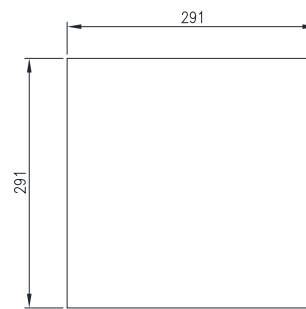

CUT-OUT DIMENSION

