

SS1 Electrical Enclosure

IP-SSL406020

STAINLESS STEEL | SINGLE DOOR | IP66

**400H x 600W x 200D
LANDSCAPE**

IP Enclosures SS1 Range of grade 316/316L Stainless Steel electrical enclosures are suitable for general industrial applications.

Protection: Complies with IP66 IK10, NEMA 4x (Independent accredited test laboratory)

Standard: IEC62208, IEC/EN/AS60529, RoHS (IEC/EN/AS61439 Compliant)



Material:

- Body: 1.5mm Grade 316/316L Stainless Steel
- Door: 1.5mm Grade 316/316L Stainless Steel
- Device Mounting Plate: 1.5mm galvanised steel sheet
- Seal: Polyurethane

Surface Finish: 0.4 micron Ra surface brushed finish.

Body: The robust monoblock body is fabricated using 1.5mm Grade 316/316L Stainless Steel. Flat face sealing surfaces are provided to increase seal life. Pre-fitted blind nutserts are incorporated to accommodate mounts and accessory fasteners to eliminate drilling and retain IP rating. Integral device plate mounts and M6 earth stud is provided. Cutting, pressing and full continuous seam welding using precision automated manufacturing equipment ensures accuracy and consistent high quality.

Door: The robust surface mounted door is fabricated using 1.5mm Grade 316/316L Stainless Steel and incorporates concealed removable hinges with captive pins. The door is designed for a 110° opening. Each door contains cable management rails, an M6 earth stud and a high quality machine-applied foamed in place (FIP) Polyurethane seal. Two internal cable management rails can be removed to provide additional space for equipment, duct and door mounted control components.

Seal: A high quality machine-applied full perimeter UL listed Polyurethane seal foamed in place (FIP) provides excellent sealing over a long life. Temperature resistance -40°C to 80°C (160°C short term loading).

Lock: 316 Stainless Steel 8mm square drive quarter turn lock with key.

Device Mounting Plate: The device mounting plate is fabricated using 1.5mm galvanised steel sheet, pressed to provide additional strength and supplied pre-fitted into enclosure as standard.

Mass: 15kg

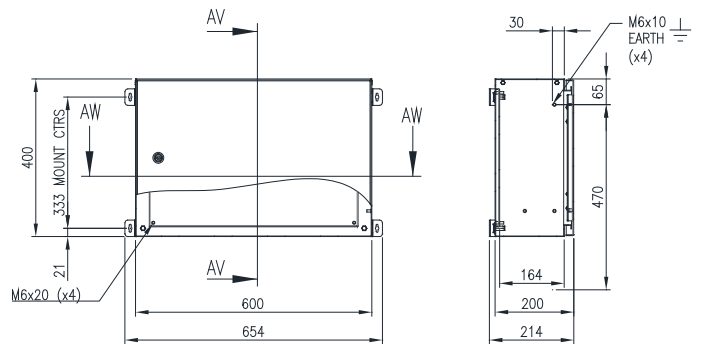

FRONT VIEW

SECTION AV-AV

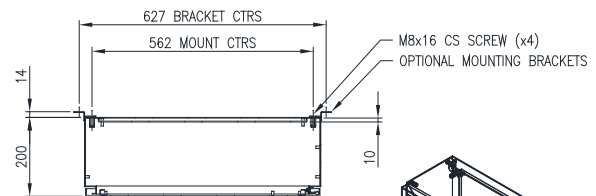

SECTION AW-AW

