

| RevNo | Revision note    | Date   | Signature | Checked |
|-------|------------------|--------|-----------|---------|
| 2     | GENERAL REVISION | 9/7/19 | IP        | IP      |

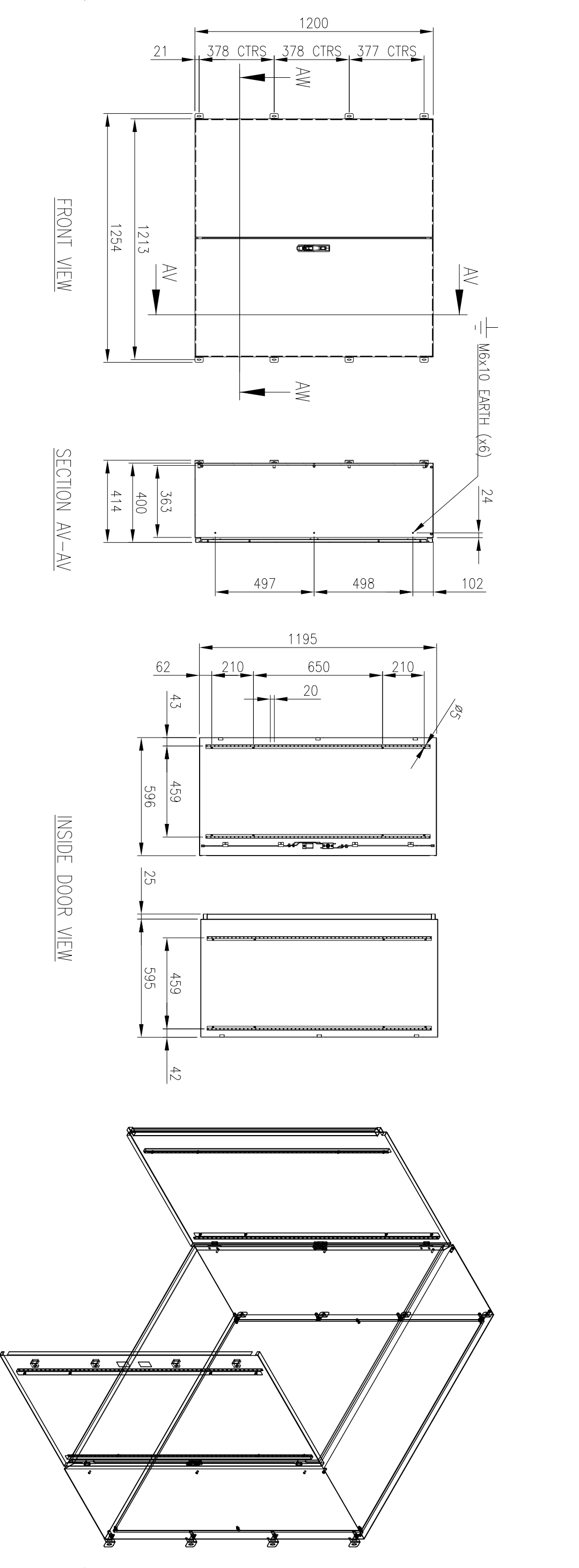

FRONT VIEW

SECTION AV-AV

INSIDE DOOR VIEW

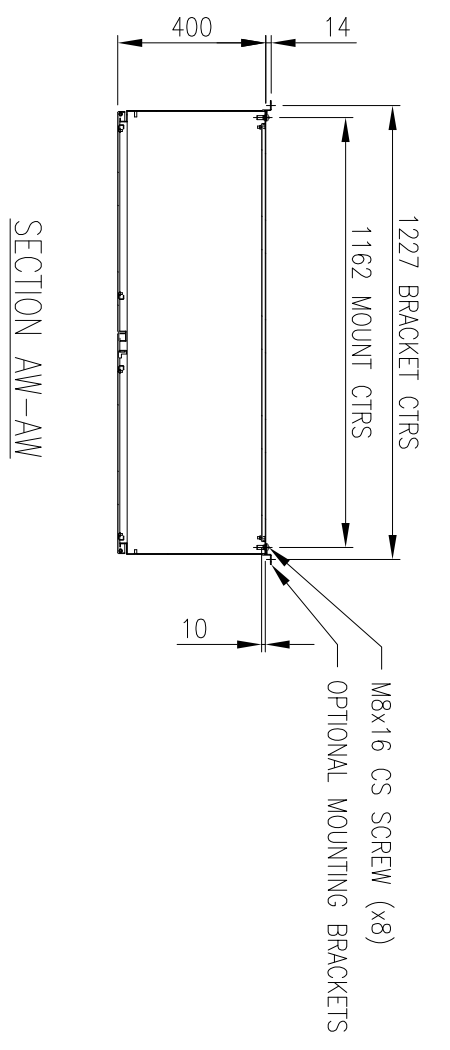

SECTION AW-AW

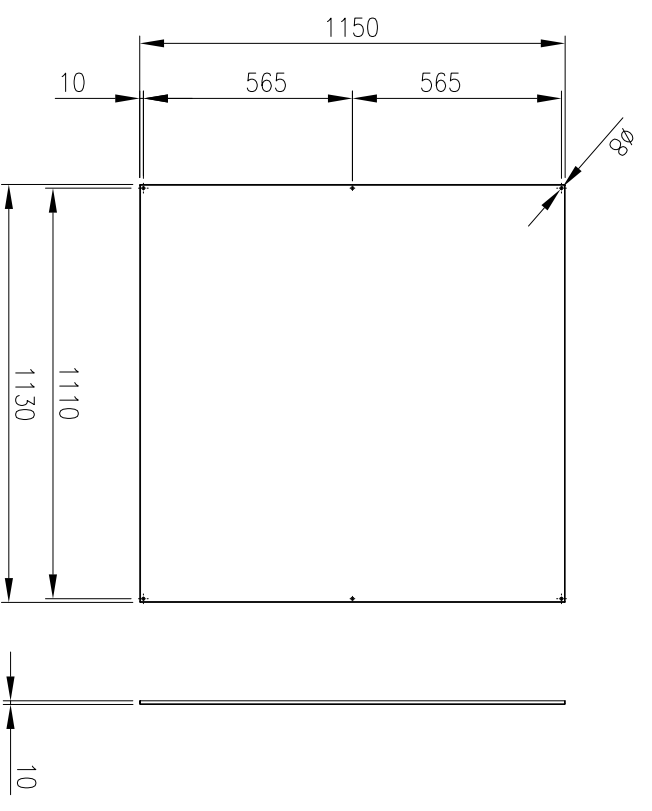

DEVICE MOUNTING PLATE

**MATERIAL**  
 BODY: 1.5mm 316 STAINLESS STEEL  
 DOOR: 1.5mm 316 STAINLESS STEEL  
 DEVICE PLATE: 1.5mm GALV STEEL  
 SEAL: POLYURETHANE

MASS: 82.0kg

PROTECTION: IP55 IK10, NEMA4x  
 STANDARD: IEC62208, IEC/EN/AS60529

© IP ENCLOSURES 2016.  
 THIS DRAWING SHALL NOT BE COPIED OR REPRODUCED  
 WITHOUT AUTHORISATION FROM IP ENCLOSURES.  
 www.ipenclosures.com.au

| Item          | Quantity   | TradeName, designation, material, dimension etc. | Article No./Reference         | Scale    |
|---------------|------------|--|-------------------------------|----------|
| IP Enclosures |            |  |                               | 1:20     |
| Designed by   | Checked by | Approved by - date                               | Filename                      | Date     |
| IP            | IP         | 17/10/16   | IP-SST020400-INT/10/16        | 17/10/16 |
|               |            |  | 1200x1200x400 316SS ENCLOSURE |          |
|               |            |  | IP-SST120120400-01            | 2        |
|               |            |  | Sheet                         | 1/1      |