

SS2 Electrical Enclosure

IP-SS10010030

STAINLESS STEEL | DOUBLE DOOR | IP55

1000H x 1000W x 300D

The SS2 range of stainless steel electrical enclosures are rated for protection up to IP55. This range is wall-mounted, grade 316L stainless steel, double door construction suitable for extreme duty applications.

Protection: IP55 IK10 (NEMA 3x)

Standards (& Conformities): IEC/EN 60529, IEC/EN 62208, IEC/EN 61439, RoHS



Material:

- Body: 1.5mm Grade 316L stainless steel (Optional 304)
- Door: 1.5mm grade 316L stainless steel (Optional 304)
- Device Mounting Plate: 1.5mm galvanised steel sheet
- Seal: Polyurethane

Surface Finish: 0.4 micron Ra surface brushed finish.

Enclosure Body: The robust monoblock body is fabricated using 1.5mm Grade 316L stainless steel (Grade 304 is also available). Flat face sealing surfaces are provided to increase seal life. Pre-fitted blind nutserts are incorporated to accommodate mounts and accessory fasteners to eliminate drilling and retain IP rating. Integral device plate mounts and M6 earth studs are provided. Cutting, pressing and full continuous seam welding using precision automated manufacturing equipment ensures accuracy and consistent high quality.

Enclosure Doors: The robust surface mounted doors are fabricated using 1.5mm Grade 316L stainless steel and incorporate concealed removable hinges with captive pins (Grade 304 is also available). The doors are designed to eliminate the central mullion to improve accessibility into the enclosure. Doors are designed for a 110° opening. Each door contains integral cable management rail studs and M6 earth studs. The cable management rails are removable to provide more space for control components.

Enclosure Seal: A high quality machine-applied full perimeter UL listed Polyurethane seal foamed in place (FIP) provides excellent sealing over a long life. Temperature resistance -40°C to 80°C (160°C short term loading).

Enclosure Lock: 3-point locking system with key-lock swing handle.

Device Mounting Plate: The device mounting plate is 1.5mm galvanised steel sheet. It is pressed to provide strength and is pre-fitted into the enclosure as standard.

Mass: 54.5Kg.

Maximum Weight of Contents: 81Kg.

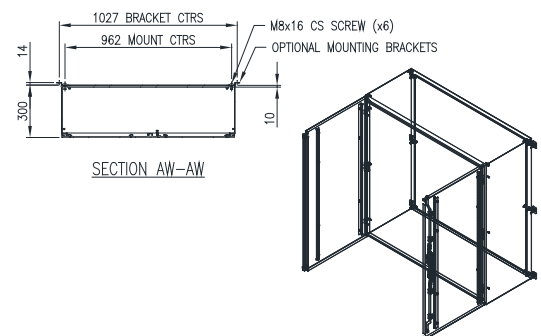
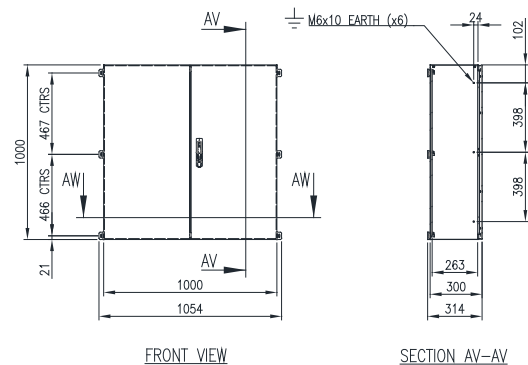

SS2 Electrical Enclosure

IP-SS10010030

STAINLESS STEEL | DOUBLE DOOR | IP55

1000H x 1000W x 300D

ACCESSORIES:

Part Number	Description
IP-EK01	Standard Earthing Kit
IP-SSWMBKIT	316 Stainless Steel Wall-Mounting Bracket Kit (with 4x Brackets and Fasteners)

CERTIFICATES:

IEC 60529 Degrees of protection provided by enclosures: Certificate AB-0386-T 1610.05.01/00
IEC/EN 62208 Empty Enclosures for low-voltage switchgear and controlgear assemblies: Certificate 0366932-TSE-01/01
IEC/EN61439-1, 61439-2 low voltage switchgear and controlgear assemblies: Certificate AB-0341-T, 23-314-R1-N1-1
CE Certificate of Compliance: Certificate SZL-21 MA 13338-1
UKCA Certificate of Compliance: Certificate SZU-22 MA 19560-1

IEC/EN 61439 Certified Test Ratings:

Rated Voltage: 400 V AC
Rated Insulation Voltage: 690 V
Rated Impulse Withstand Voltage: 6 kV
Rated Current: 630A
Rated Peak Withstand Voltage: 40kA
Rated Short-Time Withstand Current: 20kA (Busbar)
Rated Conditional Short Circuit Current: 20kA
Rated Frequency: 50Hz

Products are manufactured to Quality, Safety and Environmental Standards.

WARRANTY: 5 years.