

RevNo	Revision note	Date	Signature	Checked
1	GENERAL REVISION	9/7/19	IP	IP

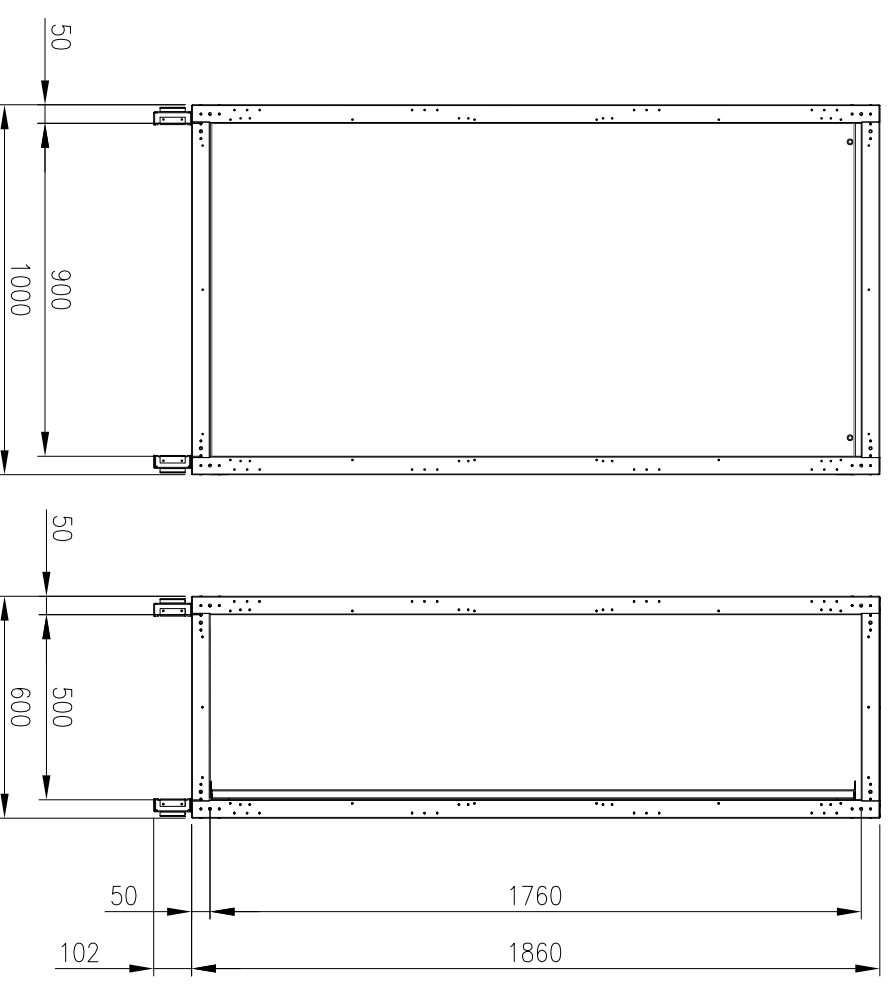
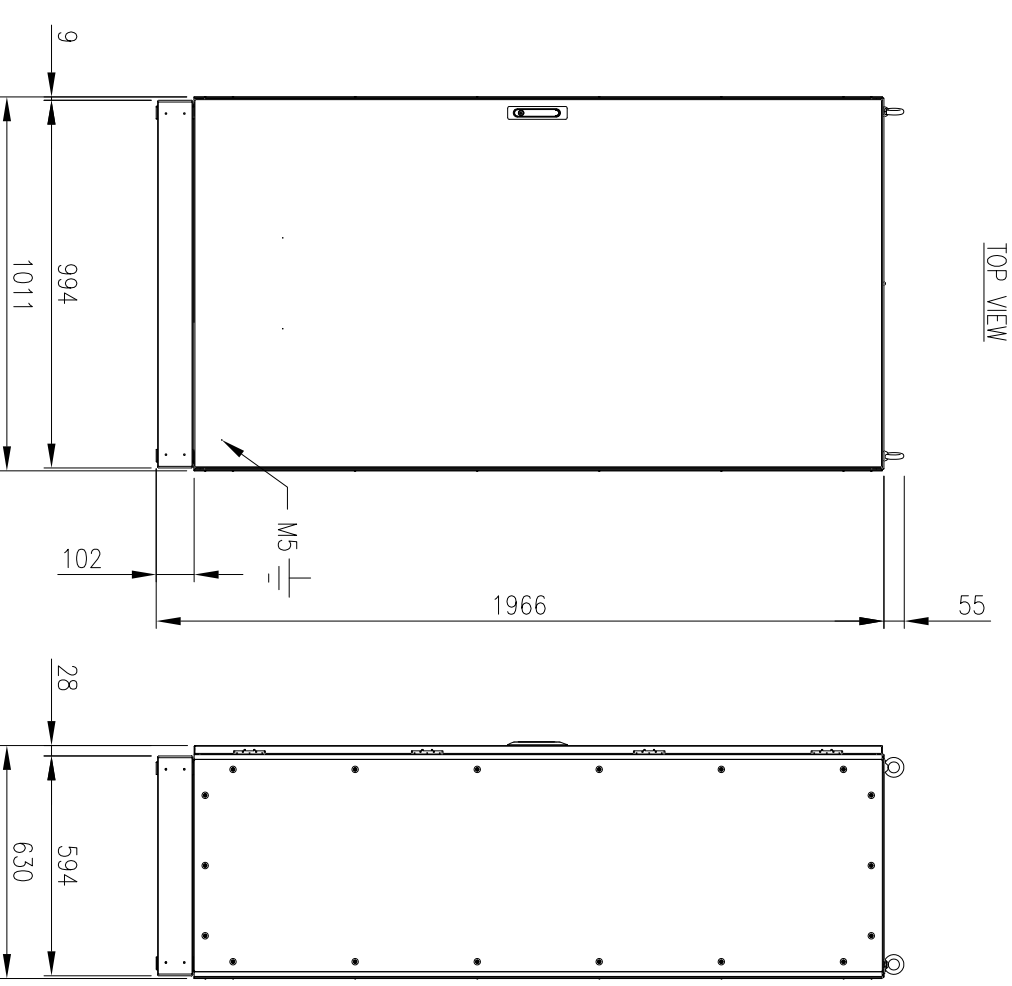
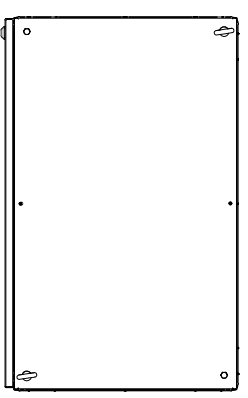
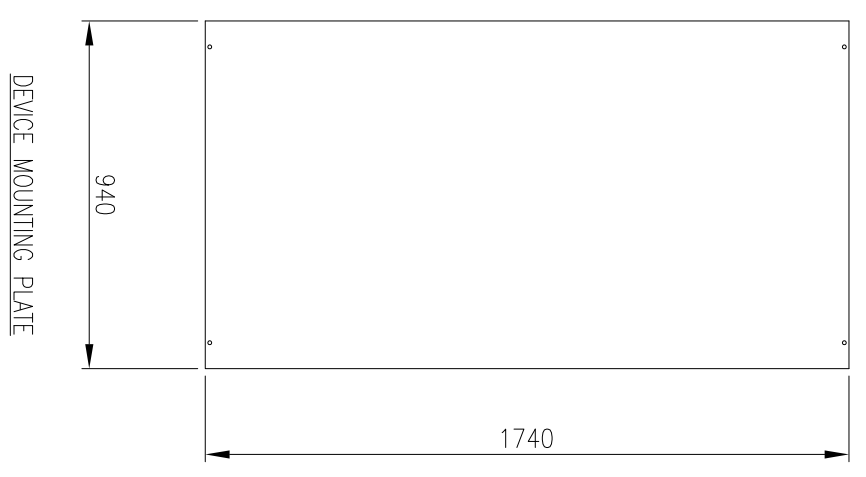
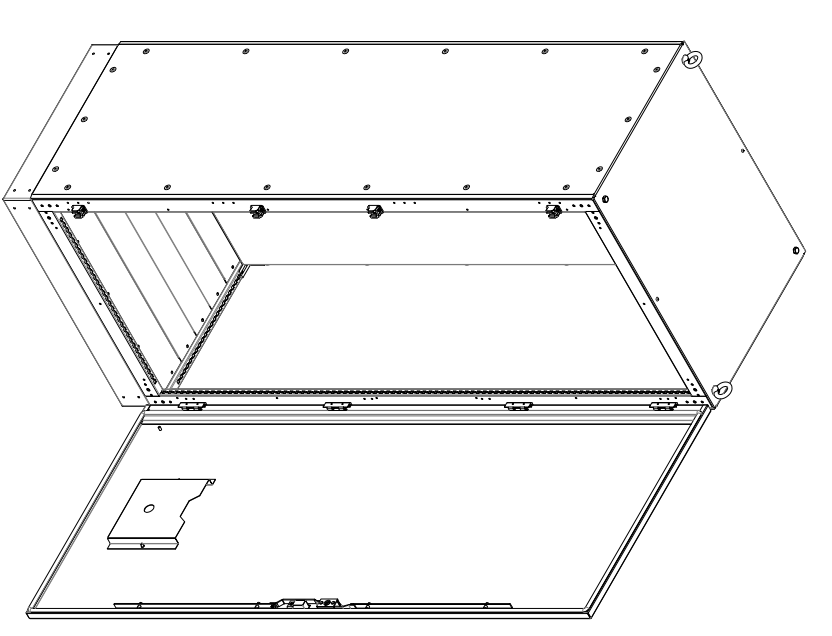

**MATERIAL**  
 MAIN FRAME: 2.0mm GALVANISED STEEL PROFILE  
 PANELS: 1.2mm POWDERCOATED GALVANISED SHEET  
 DOOR: 2.0mm POWDERCOATED GALVANISED STEEL  
 MOUNTING PLATE: 2.0mm GALVANISED STEEL SHEET  
 SEAL: EPDM  
 SURFACE TREATMENT: POWDER-COAT 80-120micron  
 STANDARD COLOUR: RAL7035

PROTECTION: IP55 IK10  
 STANDARD: IEC62208, IEC/EN/AS60529

ORDERING INFORMATION:  
 - ENCLOSURE: IP-MFS18610060  
 - SIDE PANEL: IP-MFSP18660  
 - MOUNTING PLATE: IP-MFSM186100  
 - BASE: IP-MFSB10060

© IP ENCLOSURES 2017.  
 THIS DRAWING SHALL NOT BE COPIED OR REPRODUCED  
 WITHOUT AUTHORISATION FROM IP ENCLOSURES.  
 www.ipenclosures.com.au

Item	Quantity	TradeName, designation, material, dimension etc.	Article No./Reference	Scale
IP Enclosures				1:20
1860x1000x600 STEEL FREESTANDING				
IP-MFS18610060				1/1