

## LED SURFACE MOUNTED LUMINAIRES

24V DC

**IP Enclosures provide high quality LED Surface Mounted Luminaires for electrical enclosures.**

**Features:**

- Very bright LED luminaire
- 24V DC
- Homogenous, uniform and flicker-free illumination
- Slim, almost non-protruding LED luminaire, 25mm high-clear cover, polycarbonate-material; shatterproof
- Available in clear cover glare suppression
- Quick installation (single solution/electrically interlinkable; cascable)
- Robust aluminium housing for heat dissipation
- Made in Germany

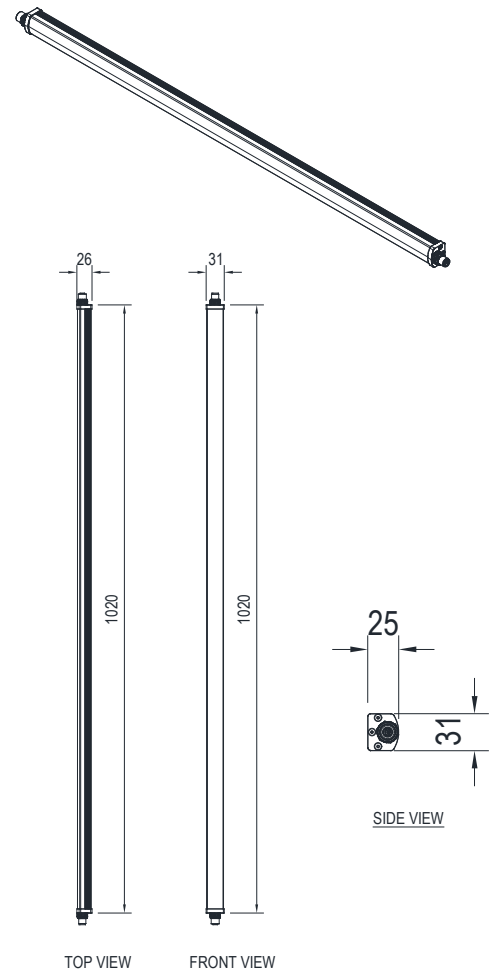

Features	Unit	IP-LED06-24VDC
Power supply	V	24V DC
Lamp luminous flux white	Lm	4008 Lm
Lamp luminous efficiency	Lm	155 Lm/W
Lamp type	-	LED Surface-mounted Luminaire
Illuminant	-	SMD LED
Light distribution	-	Direct
Light colour	-	Daylight white (5200-5700K)
Beam angle (optics)	-	120°
Colour rendering	Ra	> 85
Power consumption	W	~24 W
Service life	hr	>60, 000 h
Electrical connection	-	M12 A-type encoded
Housing material	-	Aluminium
Cover material	-	Polycarbonate, clear, shatterproof
Protection degree/Class	-	IP54 / Class III
Operating temperature	°C (°F)	-10... +60 °C (14... 140 °F)
Mounting	-	Swivel / Planar mounting
Installation	-	Electrical Interlinked
Dimensions	mm	1020(L) x 26(W) x 31(H)
Net Weight	kg	0.70
Gross Weight	kg	1.00
Risk Group (DIN EN 62471)	-	Free group
Dimmable	-	Via optional accessory
Mounting Accessories	-	2 pairs mounting holders (Holders for swivel/planar mounting) in delivery scope
Made in	-	Germany
Conformity / Certifications	-	CE, UKCA, ETL Listed