

Hygienic Electrical Enclosure

IP-H603821

STAINLESS STEEL | HYGIENIC | IP66, IP69K

600H x 380W x 210D

IP69K hygienic food grade electrical enclosures are designed to prevent contamination and are suitable for the food & beverage, pharmaceutical and other industries that require high hygienic standards.

Protection: Complies with IP66 IK07, IP69K

Standard: DGVU EN1672-2, EN62208, EN/AS60529, ISO20653, UL508A EHEDG, RoHS Compliant



Material:

- Body: 1.5mm Grade 304 Stainless Steel
- Door: 1.5mm Grade 304 Stainless Steel
- Device Mounting Plate: Galvanised Steel Sheet
- Seal: Blue Silicone FDA compliant

Body: The robust monoblock body with 30° sloping roof is fabricated using 1.5mm Grade 304 Stainless Steel. It is designed to be completely smooth and without crevices and without concave angles to facilitate cleaning and avoid deposits. The body is designed to promote self draining for ease of hygienic cleaning.

Door: The door is fabricated using 1.5mm Grade 304 Stainless Steel and includes specially cast internal hinges to allow for removal of the seals. The door is designed for a 115° opening with hinges on the right hand side.

Seal: Blue silicone seal, FDA compliant for food production areas.

Lock: IP69K Stainless Steel Hygiene lock with seal. Dirt resistant and easy to clean.

Device Mounting Plate: Fabricated using galvanised steel sheet. Supplied fitted.



Indicative Only

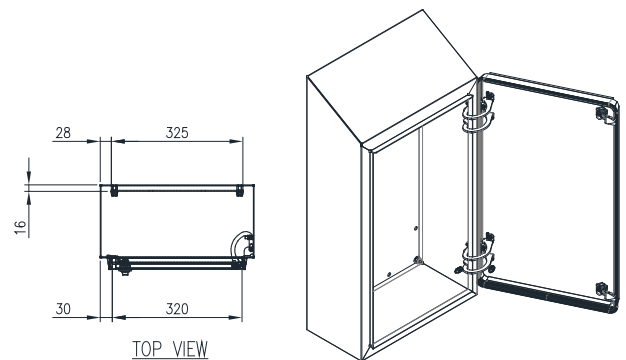

TOP VIEW

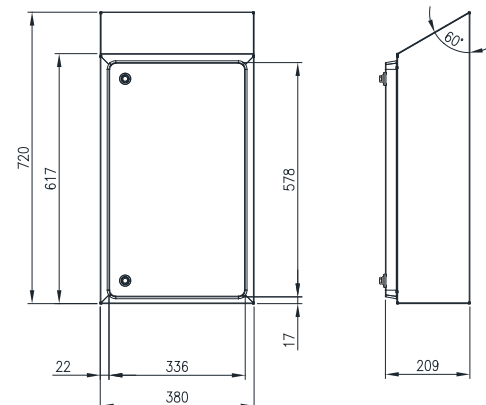

FRONT VIEW

SIDE VIEW