

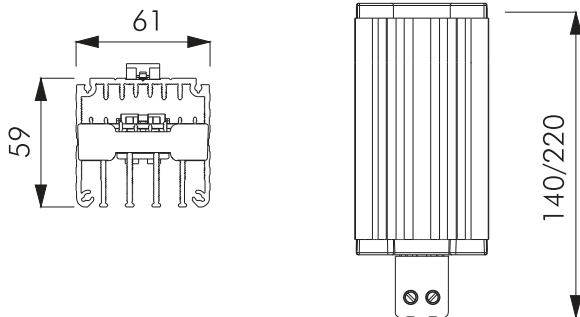

Compact | 75W to 150W

IP Enclosures provide a wide range of heating products for electrical enclosures. Anti-condensation heaters are required to prevent failures or corrosion caused by low temperatures or high humidity inside the enclosure. This occurs when ambient temperature is low and the equipment does not generate enough heat to maintain the minimum internal temperature. IP Enclosures heating products are manufactured to the highest quality in Italy.



Features	Unit	IP-H75	IP-H100	IP-H150
Heating Capacity*	W	75	100	150
Power supply	V	120-240V AC or DC		
Inrush current	A	4	5	9.5
Delayed fuse (advised)	A	6.3	8	10
Heating element type	-	PTC resistor, self regulating		
Electrical connections	-	2 screw terminals for stranded or rigid wire 2.5 mm ²		
Protection class	-	Class II		
Protection degree EN60529	-	IP20		
Operating temperature	°C (°F)	-45/+70 (-49/+158)		
Storage temperature	°C (°F)	-45/+80 (-49/+176)		
Radiator	-	Extruded aluminium profile		
Mounting	-	Clip for mounting on DIN rail 35 mm EN50022		
Installation position	-	Best efficiency in vertical position		
Dimensions HxWxD	mm	140x59x61	220x59x61	
Weight (with packaging)	kg	0.34 (0.38)	0.57 (0.62)	
Conformity/Certifications	-	CE - UL  us		

*at 20°C (68°F) ambient temperature