

# IP66 19" Data Racks

# IP-ADW15RU60-BLK

**WALL MOUNT | ALUMINIUM | SINGLE DOOR | IP66**

**19" 15RU x 600D**

**IP Enclosures Marine Grade Aluminium IP66 19" Data Racks** are designed for outdoor applications to house sensitive data network equipment in harsh environments.

**Protection:** Complies with IP66 IK10, NEMA 4

**Standard:** IEC/EN/AS60529, EIA-310-D 

**Rack Unit Size:** 15RU

**Material:**

- Body: Marine Grade Aluminium
- Door: Marine Grade Aluminium
- 19" Data Rack Rails: 1.5mm galvanised steel sheet
- Enclosure Seal: Polyurethane

**Body:** The robust monoblock body is fabricated from marine grade aluminium sheet. Precision automated manufacturing equipment ensures accuracy and consistent high quality. 19" data rack rails are fitted. 600mm deep racks include front and rear rails.

**19" Rack:** 19" Rack to EIA-310-D

**Door:** The robust surface mounted door is fabricated using marine grade aluminium and incorporates concealed removable hinges with captive pins. The door is designed for a 110° opening and contains integral cable management rail studs, M6 earth stud and a high quality machine-applied foamed in place (FIP) Polyurethane seal.

**Seal:** A high quality full perimeter seal provides excellent sealing over a long life. It is machine applied Polyurethane foamed in place (FIP).

**Lock:** 5mm Double Bit Quarter Turn Lock.

**Surface Treatment:** UL approved epoxy polyester powder coated with a textured finish. 80-120 micron average thickness.

**Colour:** RAL9005 Black

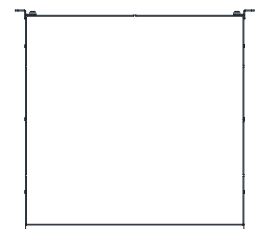
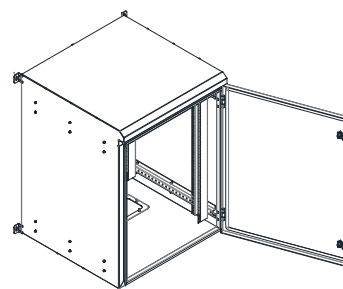

TOP VIEW

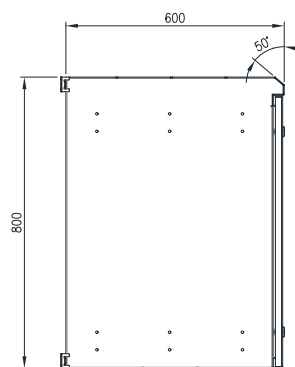

LEFT SIDE VIEW

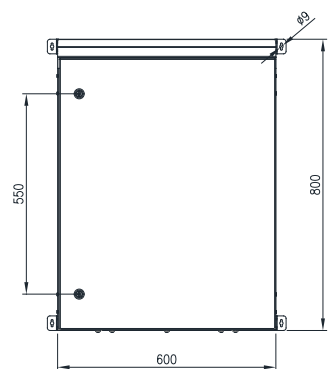

FRONT VIEW