

FCA Field Cabinet

IP-A706032-0-T33

ALUMINIUM | POLE MOUNT | NON-VENTILATED | IP66 IK10 12RU x 600W x 325D

Pole-Mounted Aluminium Field Cabinets are designed to house sensitive data network and electrical equipment for a variety of heavy duty outdoor applications including general industrial, infrastructure, road/traffic management and intelligent transport systems.

Protection: IP66 IK10

Standards (& Conformities): IEC/EN 60529, IEC/EN 62208, EIA-310-D, RoHS



Rack Unit Size: 12RU

Material:

- Body: 2.5mm Marine Grade Aluminium 5754-H111
- Door: 2.5mm Marine Grade Aluminium 5754-H111
- 19" Data Rack Rails: 1.5mm galvanised steel sheet
- Seal: Polyurethane

Body: The robust monoblock body is fabricated using 2.5mm marine grade aluminium and is pressed to provide flush recessed mounting of the door to prevent vandalism and unauthorised access. Precision automated manufacturing equipment ensures accuracy and consistent high quality. Flat face sealing surfaces increase seal life. Integral device plate mounts and M6 earth stud are included.

Door: The front door is fabricated using 2.5mm marine grade aluminium and is designed to provide flush recessed mounting to prevent vandalism and unauthorised access. The door incorporates concealed removable hinges with captive pins. It is hinged on the left side, designed for a 110° opening and is provided with a heavy duty door stay. An A4 plan pocket is provided.

Seal: A high quality Polyurethane foamed in place (FIP) full perimeter door seals provide excellent sealing over a long life.

Lock: 3 point locking system with key-lock swing handle. Optional locking including half euro keyed as required, restricted keys, Bilock and stainless steel padlockable.

19" Data Rack Rails: Front and rear 19" data rack rails are fabricated from 1.5mm galvanised steel sheet.

Surface Treatment: UL approved AkzoNobel polyester powder coated with a smooth gloss finish, 80-120 micron average thickness, providing excellent exterior durability and colour retention. Colour T33 Smoke Blue.

Mass: 16.5Kg.

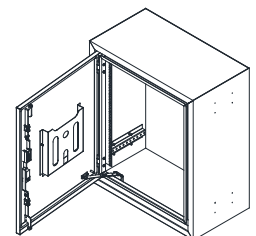
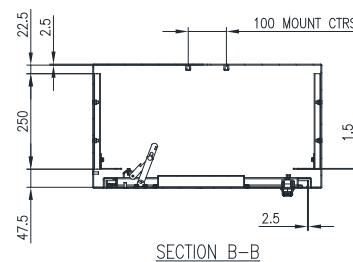
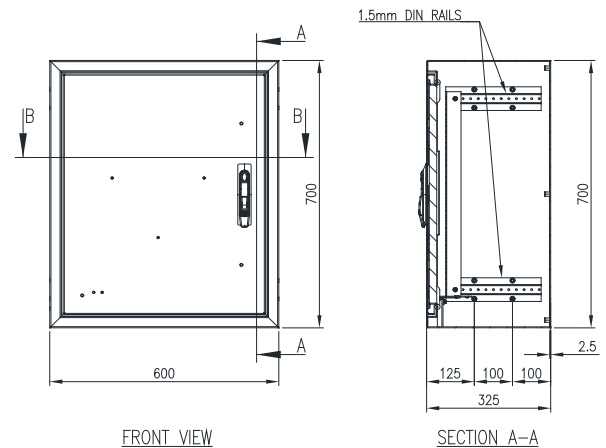

FCA Field Cabinet

IP-A706032-0-T33

ALUMINIUM | POLE MOUNT | NON-VENTILATED | IP66 IK10 12RU x 600W x 325D

ACCESSORIES:

Part Number	Description
IP-A7060VENTDOOR-T33	Aluminium Enclosure Door with Ventilation; Powder-Coated
IP-APMB70	Aluminium Pole Mount Bracket to suit 12RU x 450W x 325D Aluminium Field Cabinet
IP-FCABASE6032-T33	600H Aluminium Pedestal Base to suit 600W x 325D Field Cabinet T33 Smoke Blue

CERTIFICATES:

IEC 60529 Degrees of protection provided by enclosures: Certificate AB-0386-T 2009.33.02/00

IEC/EN 62208 Empty Enclosures for low-voltage switchgear and controlgear assemblies: Certificate 0366932-TSE-01/01

CE Certificate of Compliance: Certificate SZL-21 MA 13338-1

UKCA Certificate of Compliance: Certificate SZU-22 MA 19560-1

Products are manufactured to Quality, Safety and Environmental Standards.

WARRANTY: 5 years.