

IP66 Field Cabinet

IP-A453522-0-T33

MARINE GRADE ALUMINIUM | POLE MOUNT | IP66

**450H x 350W x 225D
Non-Ventilated**

Marine grade aluminium pole-mounted infrastructure field cabinets are designed to house sensitive data network and electrical equipment for a variety of harsh outdoor applications.

Protection: IP66 (Non-Ventilated range)

Standard: IEC62208, IEC/EN/AS60529, EIA-310-D, RoHS  

Material:

- Body: 2.5mm Marine Grade Aluminium 5754-H111
- Door: 2.5mm Marine Grade Aluminium 5754-H111
- Enclosure Seal: Polyurethane

Body: The robust monoblock body is fabricated using 2.5mm marine grade aluminium. Flat face sealing surfaces increase seal life. Pre-fitted blind nutserts are incorporated to accommodate pole mount bracket to eliminate drilling and retain IP rating. Integral device plate mounts and M6 earth stud are included.

Door: The front door is fabricated using 2.5mm marine grade aluminium and is designed to provide flush recessed mounting to prevent vandalism and unauthorised access. The door incorporates concealed removable hinges with captive pins. It is hinged on the left side and is provided with a heavy duty door stay. An A4 plan pocket is provided.

Door Seals: Polyurethane foamed in place (FIP) full perimeter door seals provide excellent sealing over a long life. Temperature resistance: -40°C to 80°C.

Locks: Single-point locking system with key-lock swing handle. Optional locking including half euro keyed as required, restricted keys, Bilock, etc.

Surface Treatment: UL approved epoxy polyester powder coated with a smooth finish. 80-120 micron average thickness. Colour T33 Smoke Blue.

Accessory: Optional Pole Mount Bracket (One-piece, full height). Optional Base: 600mm high base, flush to suit width and depth of field cabinet. Powder coated, colour T33 Smoke Blue.



TOP VIEW

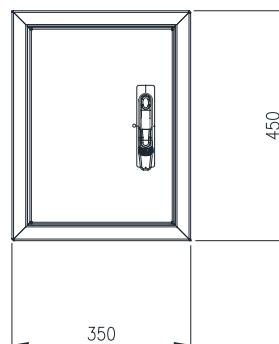
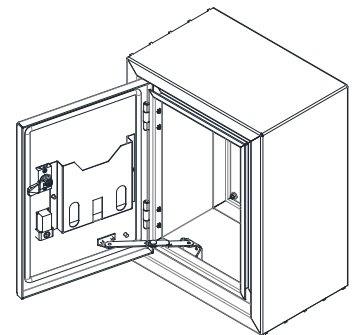

FRONT VIEW



SIDE VIEW