

IP55 19" Field Cabinet

IP-A16715080-T33

ALUMINIUM | DOUBLE BAY 19" | IP55

19" 30RU - 1675H x 1500W x 800D
Ventilated

IP Enclosures marine grade aluminium Infrastructure Field Cabinets are available in ventilated and non-ventilated double bay configurations.

Protection: Complies with IP55

Standard: IEC62208, IEC/EN/AS60529, EIA-310-D, RoHS

Rack Unit Size:



TOP VIEW

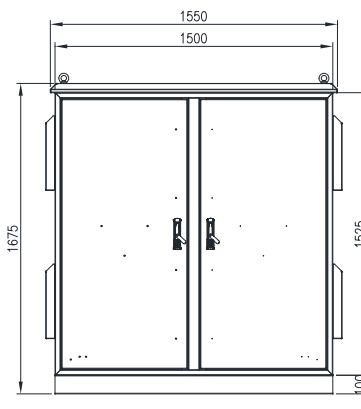
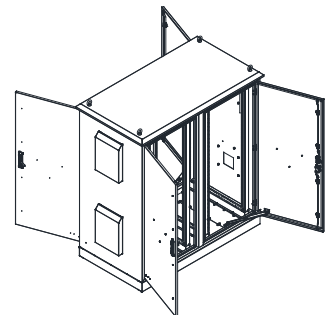

FRONT VIEW

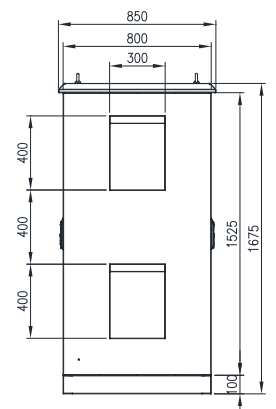

RIGHT SIDE VIEW