

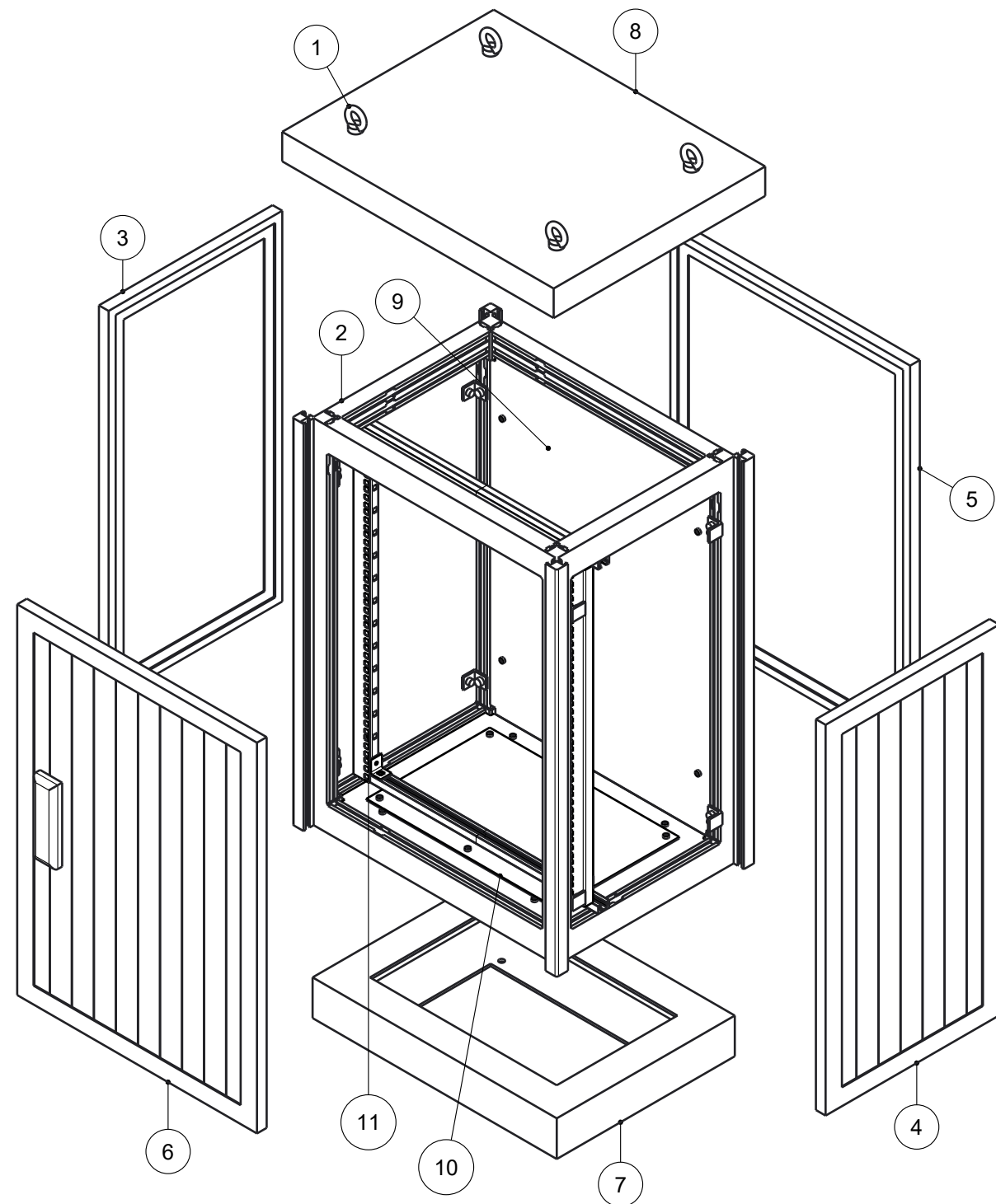

INDEX	NUMBER	DATE	VISUM	NICHT VERMASSTE RADII NOT DIMENSIONED RADIUS	R5	MATERIAL	ERP NUMBER				
-	-	-	-	KANTEN GEBROCHEN SHARP EDGES REMOVED	0.2...0.4	GEW./MASS 126.072 kg	ERP RAW NR.	UNLESS OTHERWISE SPECIFIED DIMENSIONS EXPRESSED IN METRIC			
-	-	-	-	DREHMOMENT NACH TORQUE ACCORDING TO	AAW_0002			APPROVALS	DATE		
-	-	-	-	GENERAL TOLERANCES / ALLGEMEINTOLERANZEN		FINISH ACCORDING TO AAW_0005	DRAWN raja	17.06.24	Almatec AG Industriestrasse 12 CH-6170 Schüpfheim Switzerland		
-	-	-	-	ISO 2768 - m L						CHECKED & RELEASED	
-	-	-	-	WELD SYMBOLS / SCHWEISSSYMBOLS		EN 22553	-	-	SCALE 1:10	RELEASE STATUS	SHEET
-	-	-	-								

THIS DRAWING AND THE DESIGN SHOWN HERE ON ARE THE EXCLUSIVE PROPERTY OF ALMATEC SWITZERLAND. ITS CONTENTS CANNOT BE COPIED, COMMUNICATED OR REPRODUCED IN ANY FORM, FOR ANY PURPOSE, WITHOUT PRIOR SPECIFIC WRITTEN CONSENT FROM ALMATEC SWITZERLAND.
DIESE ZEICHNUNG UND IHR INHALT STEHEN UNTER DEM ALLEINIGEN RECHT DER FIRMA ALMATEC SWITZERLAND. DIE ZEICHNUNG UND IHR INHALT DÜRFEN IN KEINER FORM KOPIERT, WEITERGEGEBEN, ODER REPRODUZIERT WERDEN, OHNE DIE SCHRIFTLICHE ZUSTIMMUNG DER FIRMA ALMATEC SWITZERLAND.



ITEM NO	Part number	QTY Stk.	Description Benennung	Weight Gewicht kg / Part
1	012877	4	Ringschraube M10	0.102
2	1581900	1	Dummy ANK Ständer	21.556
3	1581901	1	Dummy ANK Seitenwand links 800x450	13.417
4	1581902	1	Dummy ANK Seitenwand rechts 800x450	13.417
5	1581903	1	Dummy ANK Rückwand 600x800	18.241
6	1581910	1	Dummy ANK Türe 1-flügelig	18.663
7	1581911	1	Dummy ANK Sockel 600x80x450	5.286
8	1581912	1	Dummy ANK Flachdach 58 600x450	28.041
9	1582857	1	ANK Montageplatte 600x800	2.990
10	1583593	1	ANK Bodenblech aufgesetzt 600x450 mit Flanschplatte	1.883
11	1585514	1	19" Einbau 600x800x450	1.924

INDEX	NUMBER	DATE	VISUM	NICHT VERMASSTE RADIIEN NOT DIMENSIONED RADIUS R5	MATERIAL	ERP NUMBER	UNLESS OTHERWISE SPECIFIED DIMENSIONS EXPRESSED IN METRIC		 Almatec AG Industriestrasse 12 CH-6170 Schüpfheim Switzerland	ALMATEC IDENT NUMBER	REV
-	-	-	-	KANTEN GEBROCHEN SHARP EDGES REMOVED DREHMOMENT NACH TORQUE ACCORDING TO AAW_0002	126.072 kg	ERP RAW NR.	APPROVALS	DATE		SIZE	1581897
-	-	-	-	GENERAL TOLERANCES / ALLGEMEINTOLERANZEN ISO 2768 - m L	FINISH ACCORDING TO AAW_0005	DRAWN	raj	17.06.24	A3	RELEASE STATUS	2/3
-	-	-	-	WELD SYMBOLS / SCHWEISSYMBOLS EN 22553		CHECKED & RELEASED	-	-	SCALE	Wird bearbeitet	



THIS DRAWING AND THE DESIGN SHOWN HERE ON ARE THE EXCLUSIVE PROPERTY OF ALMATEC SWITZERLAND. ITS CONTENTS CANNOT BE COPIED, COMMUNICATED OR REPRODUCED IN ANY FORM, FOR ANY PURPOSE, WITHOUT PRIOR SPECIFIC WRITTEN CONSENT FROM ALMATEC SWITZERLAND.
 DIESE ZEICHNUNG UND IHR INHALT STEHEN UNTER DEM ALLEINIGEN RECHT DER FIRMA ALMATEC SWITZERLAND. DIE ZEICHNUNG UND IHR INHALT DÜRFEN IN KEINER FORM KOPIERT, WEITERGEGEBEN, ODER REPRODUZIERT WERDEN, OHNE DIE SCHRIFTLICHE ZUSTIMMUNG DER FIRMA ALMATEC SWITZERLAND.

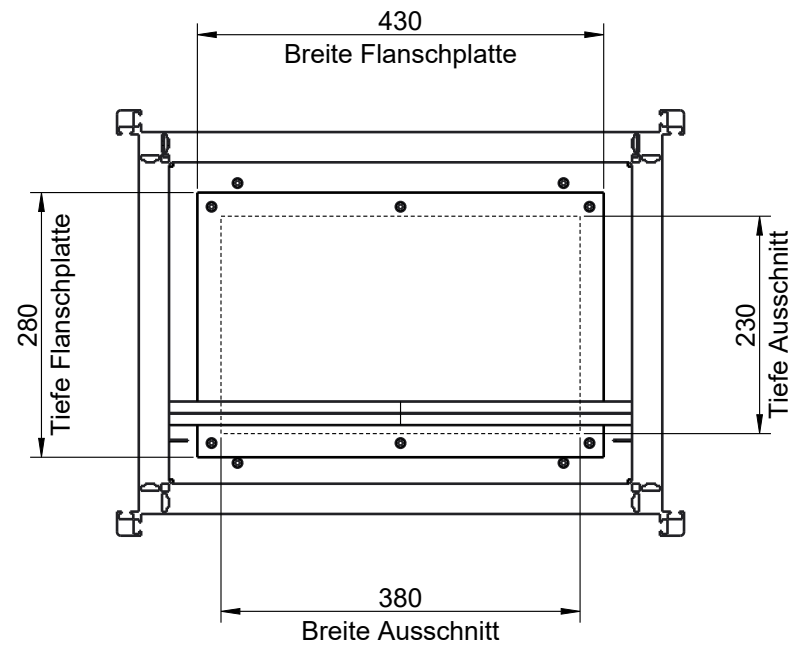
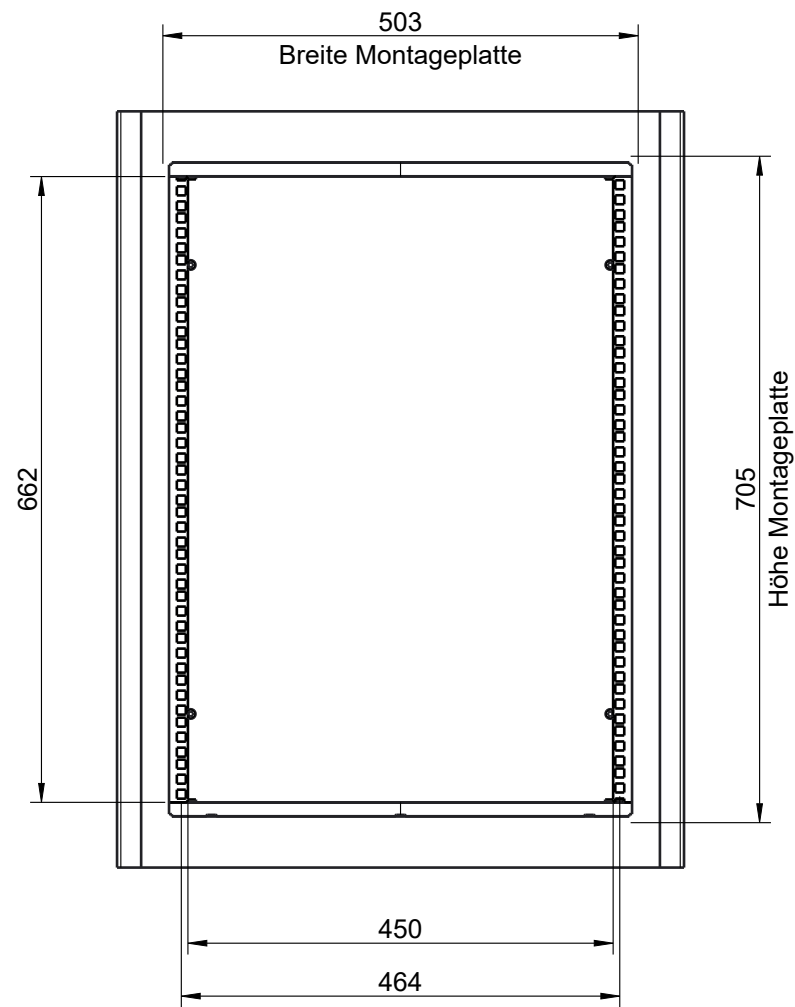

INDEX	NUMBER	DATE	VISUM	NICHT VERMASSTE RADIIEN NOT DIMENSIONED RADIUS R5	MATERIAL	ERP NUMBER		
-	-	-	-	KANTEN GEBROCHEN SHARP EDGES REMOVED 0.2...0.4		ERP RAW NR.		
-	-	-	-	DREHMOMENT NACH TORQUE ACCORDING TO AAW_0002	GEW./MASS 126.072 kg	UNLESS OTHERWISE SPECIFIED DIMENSIONS EXPRESSED IN METRIC	APPROVALS	DATE
-	-	-	-	GENERAL TOLERANCES / ALLGEMEINTOLERANZEN	FINISH ACCORDING TO AAW_0005	DRAWN	raja	17.06.24
-	-	-	-	ISO 2768 - m L		CHECKED & RELEASED	-	-
-	-	-	-	WELD SYMBOLS / SCHWEISSYMBOLS EN 22553				

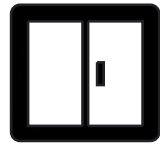

Almatec AG
Industriestrasse 12
CH-6170 Schüpfheim
Switzerland

ALM-ANK806045 800H x 600W x 450D DOUBLE WALL ALUMINIUM CABINET		
SIZE	ALMATEC IDENT NUMBER	REV
A3	1581897	-
SCALE	RELEASE STATUS	SHEET
1:8	Wird bearbeitet	3/3